

What's inside the toolbox?

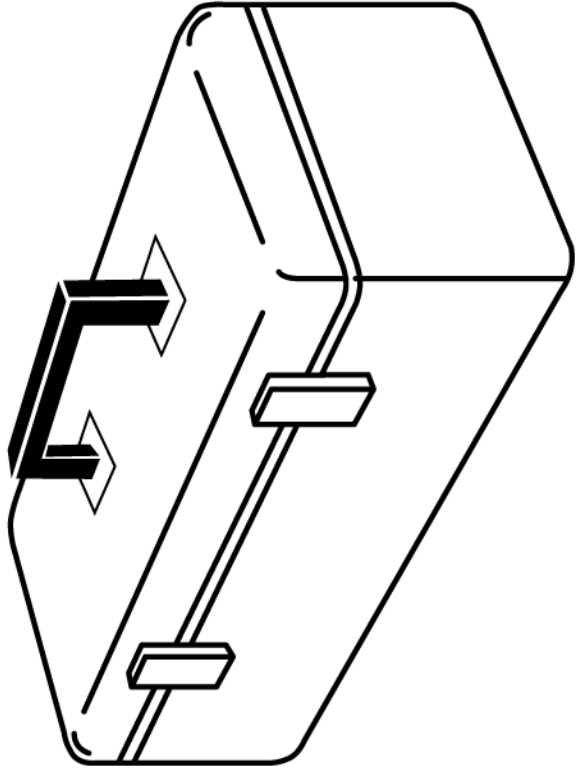

 **NOGGIN.COM**  
Everyday something new to think and do.  
**PRINTABLE #020**

Invite your child to color the pictures, then fold the paper in quarters so the toolbox is on the outside. Then ask your child "What's inside?" and open the card to reveal the tools.

NOGGIN® and all related titles, characters and logos are trademarks of Viacom International Inc.  
© 2002 Noggin L.L.C. All rights reserved.



# What's Inside? – Toolbox

Fold the paper to make a picture riddle.

## SET UP\*

You will need:



or

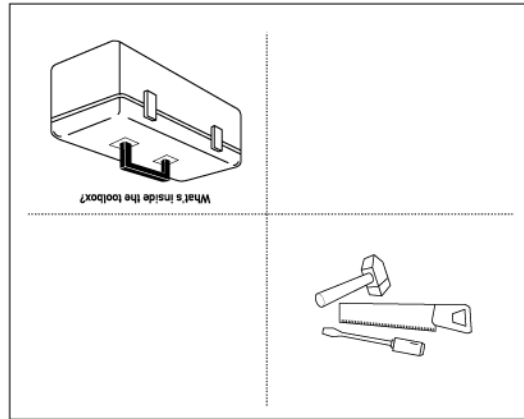

## WHAT TO DO

Discuss with your child what the pictures on the page are (toolbox and tools). Talk about how the two pictures relate to each other. Then have your child color them.

Fold the paper in quarters, or help your child fold it, so that you can see the picture of the toolbox on the outside of the card, and the tools appear on the inside of the card when you open it.

Ask the riddle: **What's inside a toolbox?** Your child can open the card to reveal the answer.

## FOLLOWING UP

Ask: **What are the names of these different tools? How are they used? Which ones are sharp? Which ones are heavy? Can you think of any other tools besides these?**

## LEARNING GOALS

Making connections, and sorting items according to uses or characteristics, encourage logical thinking.

\*



=scissors



=markers



=crayons



=pencil or pen



=tape



=leaves



**NOGGIN.COM**  
Everyday something new to think and do.  
**PRINTABLE #020**